



WINCH MOUNT INSTALLATION INSTRUCTIONS

09-10 Ranger 500, 2009 Ranger 700

NOTE: Fairlead is not included with this kit.

10-14 Ranger 800, 2011 Ranger Diesel

PART# 4505-0689

ITEM	QTY.	PART#	DESCRIPTION
1	1	1615-1	Winch Mount Plate
2	4	HDW7058	5/16 Nylock Nut
3	4	HDW2050	5/16 x 3/4 Hex Bolt
4	2	HDW9002	5/16 Flat Washer

1. Remove the front metal screen from underneath the hood latch area and retain the hardware. Remove the one-piece front bumper assembly and retain the hardware.
2. Loosely install the back tabs of the main winch mount plate on the frame rail just beneath the radiator per the illustration. Hand tighten only with two 5/16" x 3/4" hex bolts (#3), flat washers (#4), and 5/16" nylock nuts (#2).
3. Set your winch in place on top of the mount plate but do not bolt in yet. Make sure to orientate your winch so the cable pulls off the bottom of the drum. Pull a small amount of cable out through the fairlead hole in the mount plate.
4. Put the front bumper back in place on the machine but do not tighten the bolts yet. Using two 5/16" x 3/4" hex bolts (#3) and 5/16" nylock nuts (#2), bolt the front bumper to the two upper corners of the winch plate on each side of the fairlead. Hand tighten only. See Illustration.
5. This mount accepts wide and narrow fairleads. Use the hardware provided with winch to mount fairlead.
6. You can now tighten all the bolts starting with the front bumper, front winch plate mount bolts, rear winch plate mount bolts, and roller fairlead bolts.
7. Using the hardware that came with your winch, bolt the winch to the plate. Using the instructions provided with the winch, wire accordingly.
8. Reinstall front metal screen using original hardware. Reinstall stock large black Torx bolts into the two remaining holes in the front of the winch mount

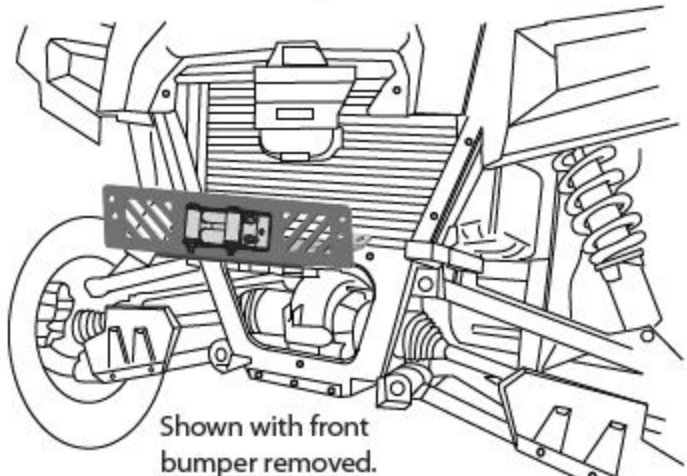
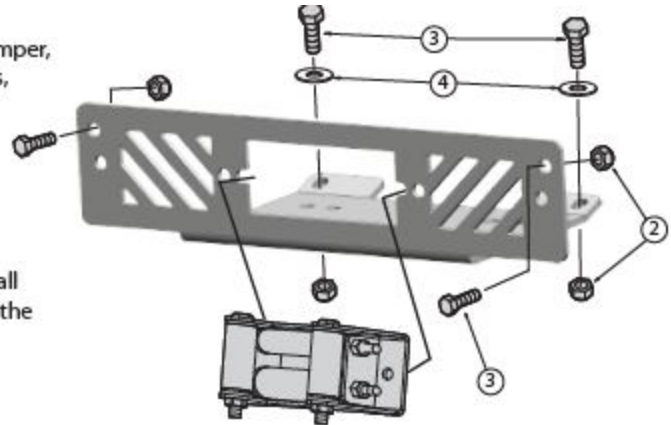

FOR QUESTIONS OR COMMENTS PLEASE CALL: 320-964-1616 (7:00 to 4:30 CST Monday through Thursday).

INST1615PF